

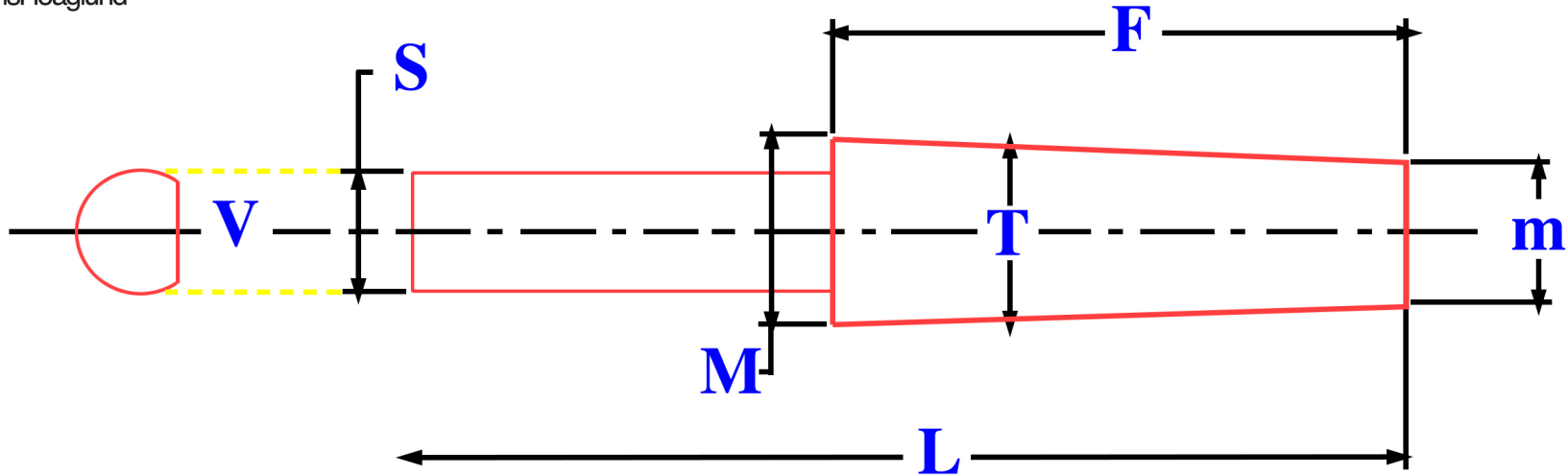

the GAMMONS[®] Hoaglund Company

Taper Reamer, Straight Shank

Note:
These templates are
not drawn to scale.



S:	Shank Diameter	T:	Flute Taper Angle	Helix: ✓ one	Style: ✓ one
M:	Major Diameter	L:	Overall Length	Right	Roughing
m:	Minor Diameter	V:	# of Flats on Shank (0 through 6)	Left	Finishing
F:	Flute Length			Straight	

Company Name

Phone Number

Comments

Quantity Needed

Contact

Email Address

Click Submit to send us your
specs for quotation.

253 Broad Street, Manchester, CT 06040

sales@gammons.com

Phone: 800.842.9446 | 860.432.0252 | 860.646.4483 Fax